



first  **seals**TM
Division

www.first4seals.com



first4seals Product Range

AESSEAL Marine plc, Unit 4 Venlo Industrial Estate, Knowles Street, Bradford, BD4 6HA, United Kingdom

Tel: +44 (0) 1274 720775 Fax: +44 (0) 1274 729022

Email: seals@first4seals.com - Web: www.first4seals.com

About Us

first4seals plc has over 25 years' experience in the mechanical seal industry. We take pride in providing affordable, quality products and an excellent standard of service to our customers.

We recently invested in new premises and are proud to have a world class seal assembly and repair workshop. This facility includes a state-of-the art stock management system incorporating automated carousels, in addition to individual booths to segregate workshop processes.

Our extensive product range consists of Single Spring, Component and Cartridge Seals (available in both rotary and stationary arrangements). We also offer Seal Support Systems to suit some of the industry's most demanding applications. We are committed to offering products that protect the environment by reducing pollution and emissions from rotating equipment.

Single Spring Mechanical Seals

In order to compete in a competitive market it is vital to continuously improve and do things better, faster and more cost effectively. This is one of the reasons that in 2016 we implemented our own range of build-to-order single spring seals. This provides our customers with:

- Better quality and traceability. The seals are assembled in our UK workshop facility from components that have been manufactured in our group's world class manufacturing facilities. We can offer superior quality and traceability back through the supply chain to the raw materials used to produce the component.
- Better service. Holding stock in component form allows us greater product flexibility and availability.
- Better price. Quantity sensitive pricing and improved cost base means we can offer competitive prices.

We also have products in material combinations to suit many applications and pumps including:

- Alfa Laval®
- KSB®
- Grundfos®
- Hilge®
- APV®
- Fristam®
- Hidrostat®
- Lowara®
- Flygt®
- Waukesha®



We offer interchangeable equivalents to many competitor seal designs including:

- Eagle Burgmann®
- John Crane®
- Flowserve®
- Roten®
- Vulcan®



212U equivalent to U.S.SEAL® Type D



290 equivalent to John Crane® Type 109

Food Safe Seals

An EU food safety regulation (EC1935/2004) is aimed at ensuring that products intended for use with foodstuffs are not hazardous to human health. In order to supply or use mechanical seals on food applications in the EU, you must be able to prove that they are constructed from certified materials. We offer a comprehensive range of seals that comply with food safety standard (FDA, FSA and EC1935/2004).

Component Mechanical Seals

SME™ - A hydraulically balanced external rotary single component mechanical seal for use with a number of stationary face arrangements. Available in shaft sizes 1.000" – 4.000" / 25mm – 100mm. Larger sizes can be manufactured to order.

Stationary options – the SME™ seal is available with V or VA type stationary (John Crane® V seat). Please see our Single Spring Seal brochure for more information.

SMI™ - A hydraulically balanced internal rotary single component mechanical seal for use with a number of stationary face arrangements. Available in shaft sizes 0.750" – 4.000" / 19mm – 100mm. Larger sizes can be manufactured to order.

Stationary options – the SMI™ seal is available with DIN and H (John Crane® W seat) type stationary options. Please see our Single Spring Seal brochure for more information.



Single Rotary Cartridge Seals

MV™ - Designed as a compact single rotary cartridge seal to fit most pump installations, the MV™ is an excellent general purpose single sealing solution that features an elliptical 2-bolt gland design. The MV™ is a recommended upgrade from an existing packed stuffing box or single spring arrangement. Available in shaft sizes 1.000" – 3.125" / 24mm – 80mm. Larger sizes can be manufactured to order.

303A™ - Designed as a short working length single rotary cartridge seal to fit most pump installations, the 303A™ is an excellent general purpose sealing solution. It incorporates a Flush connection and self aligning faces as standard. Available in shaft sizes 0.625" – 3.125" / 16mm – 80mm.

301A™ – As per 301 with the addition of a ¼" BSP Flush port to allow the introduction of a fluid to cool the stuffing box and/or remove abrasives from the seal face area. Available in shaft sizes 0.625" – 5.000" / 16mm – 125mm. Larger sizes can be manufactured to order.

301B™ – As per 301A™ with the addition of Quench and Drain ports to allow the introduction of a fluid on the atmospheric side of the seal faces for additional cooling and/or lubrication. Available in shaft sizes 0.625" – 5.000" / 16mm – 125mm. Larger sizes can be manufactured to order.

301C™ - The 301C™ is a hydraulically balanced single cartridge mechanical seal of rotary design, with self aligning faces. The 301C™ cartridge seal incorporates a conical lip seal which allows a buffer fluid to be added to protect the faces from crystallisation, vacuum and dry running. Available in shaft sizes 0.625" – 5.000" / 16mm – 125mm.

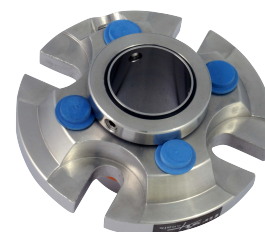
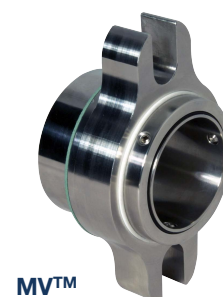

301A™ & 301B™

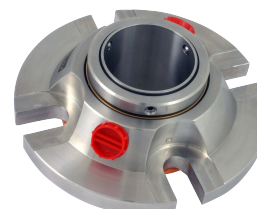

301C™



302™

Double Rotary Cartridge Seals

302™ – A face-to-face double rotary cartridge seal that has been designed for hazardous and aggressive sealing applications in Chemical and Process Industries. It possesses design features essential for applications where safety is the prime consideration. Available in shaft sizes 0.625" – 5.000" / 16mm – 125mm. Larger sizes can be manufactured to order.

The patented pumping action allows cool running to be achieved, thereby extending seal life, whilst the double balanced design allows up to 30 bar (440 psi) product or barrier pressure to be accommodated.

Single Stationary Cartridge Seals

f4s100™ - Hydraulically balanced single stationary cartridge seal with flush environmental control and setting clips. Available to suit standard seal chamber designs in 1.000" – 3.375" / 24mm – 85mm shaft sizes.



f4s100™

Double Stationary Cartridge Seals

f4s200™ - A face-to-face double stationary cartridge seal that has been designed for hazardous and aggressive sealing applications in Chemical and Process Industries. Available to suit standard seal chamber designs in 1.000" – 3.375" / 24mm - 85mm shaft sizes.

It possesses design features essential for applications where safety is the prime consideration. The patented pumping action allows cool running to be achieved, thereby extending seal life, whilst the double balanced design allows up to 30 bar (440 psi) product or barrier pressure to be accommodated.



f4s200™

Seals to suit ANSI+ Pumps

As standard, first4seals offers the stationary seal range seals to suit ANSI+ pumps.

The **f4s100™** is a hydraulically balanced single stationary cartridge seal, with environmental Flush control and setting clips to specifically suit ANSI+ seal chamber designs. Available in shaft sizes 1.125" – 2.750".

The **f4s200™ ANSI+** is a face-to-face double stationary cartridge seal that has been designed specifically to suit ANSI+ seal chambers for hazardous and aggressive sealing applications in Chemical and Process Industries. It possesses design features essential for applications where safety is the prime consideration. The patented pumping action allows cool running to be achieved, thereby elongating seal life, whilst the double balanced design allows up to 30 bar (440 psi) product or barrier pressure to be accommodated. Available in shaft sizes 1.125" - 2.750".

We can also offer special ANSI+ designs based on our 301™ range, 303A™ and 302™ rotary cartridge seals. Please contact our technical team for more information technical@first4seals.com

Progressive Cavity Pump (PCP) Seals

first4seals Progressive Cavity Pump mechanical seals have been developed from the proven modular designs of our highly-acclaimed range of single and double mechanical seals. Designs are available to suit all major PCP manufacturers including Mono®, Netzsch®, Seepex®, Orbit® and many more.

Features:

- Available in single or double seal options
- No pump modification necessary, reducing cost of conversion
- Components are modular to standardize seal ranges
- Big bore flared housing maximizes cooling and lubrication, increasing seal life and prevents clogging

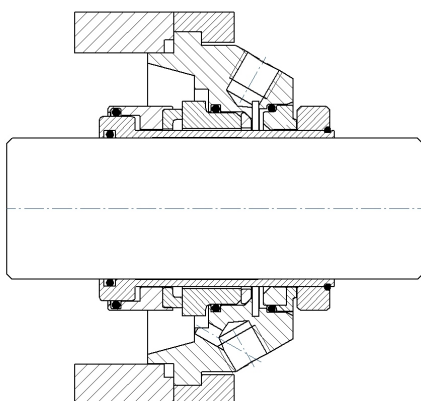

43mm 301B™ to suit Netzsch® NM045B

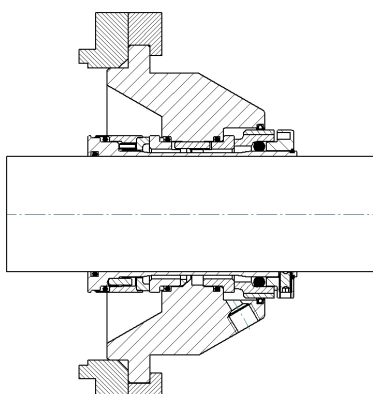

55mm 302™ to suit Netzsch® NM076S

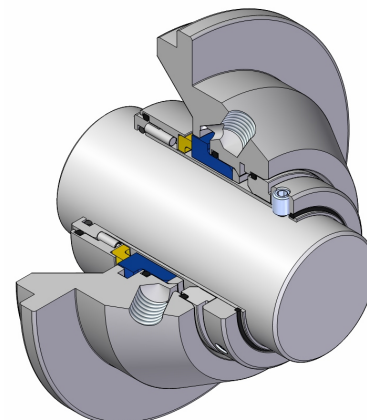

Seal Support Systems

f4s25™ & f4s25CC™ systems:

A range of seal support systems including a 25 litre (6.6 US Gallons) vessel with or without cooling coil to cover demanding applications, offering fast and problem free installation on site. These are supplied with all the necessary components and fittings. Various hose kits are available including polyamide and flexible braided stainless steel. Available to US markets only.

f4s10™ & f4s10CC™ systems:

As per f4s25 but includes a 10 litre (2.6 US Gallons) vessel with or without cooling coil to cover most standard or lower temperature applications.

Standard Buffer system:

May be used unpressurised to provide cooling on medium temperature applications, to prevent crystallisation of aqueous solutions, or to provide protection from dry-running damage.

This includes:

- 1 off vessel
- 1 off ball/drain valve
- 1 off level gauge/sight glass
- 1 off ball/fill valve
- 1 off polyamide pipe kit with fittings

Standard Water retention systems:

Water retention systems are connected directly to a suitable clean water supply (subject to local regulations) to form a low maintenance, high reliability barrier fluid system. In normal operation the supply pressurises the vessel, but negligible water is drawn. The 'Thermosyphon' effect (natural convection) ensures the seal is kept cool.

When the flow indicator eventually shows water is being drawn from the supply, this indicates the need to consider seal replacement. In the meantime the integrity of the barrier is maintained to extend seal life and prevent any loss of product.

This includes:

- 1 off vessel
- 1 off ball/drain valve
- 1 off level gauge/sight glass
- 1 off pressure gauge
- 1 off water regulator
- 1 off water supply connection
- 1 off non return valve
- 1 off flow indicator
- 1 off polyamide pipe kit with fittings
- 1 off 3 way valve

Standard Gas/air pressurised systems:

Pressure systems are partially filled with a suitable fluid then pressurised via a connection to a factory air or nitrogen supply. Alternatively, the system can be pressurised from a mobile nitrogen cylinder. Again, the seal is cooled by the 'Thermosyphon' effect.

This includes:

- 1 off vessel
- 1 off ball/drain valve
- 1 off level gauge/sight glass
- 1 off ball/fill valve
- 1 off air/nitrogen regulator
- 1 off relief valve
- 1 off polyamide pipe kit with fittings
- 1 off pressure gauge
- 1 off 3 way valve

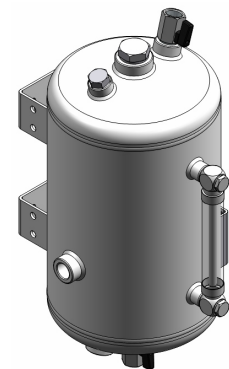

f4s-10™ & f4s-10CC™

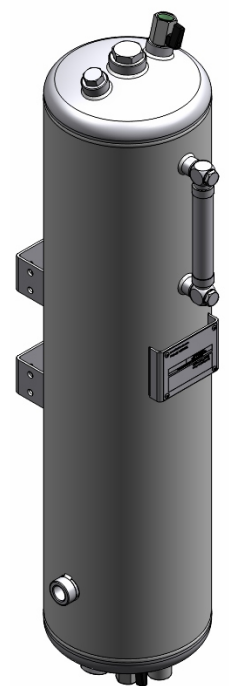

f4s-25™ & f4s-25CC™

Vessel code:

The f4s10™ & f4s25™ vessels are designed and manufactured in accordance with ASME VIII Div1 (not stamped) and comply with PED97/23/EC.

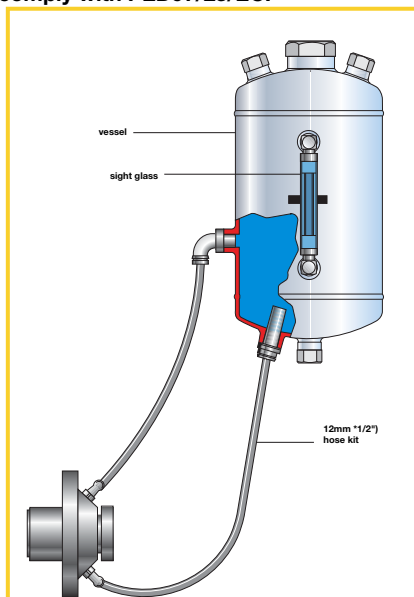

f4s-10 basic vessel

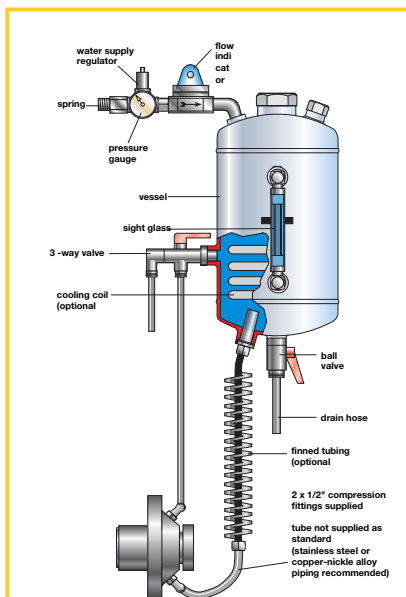

f4s-10 with water retention system options

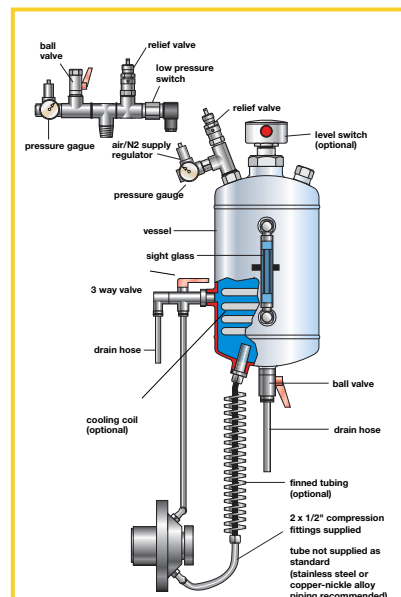

f4s-10 with pressure system options

Mechanical Seal Repairs

In 2016 we invested in new premises and are proud to have a world class seal assembly and repair workshop. This facility includes a state-of-the-art stock management system incorporating automated carousels in addition to individual booths to segregate workshop processes.

Seal assessment

Each seal is cleaned to remove any chemicals or hazardous materials upon arrival and then individually inspected and assessed. The assessment process determines which components require replacement or refurbishment in order to generate an accurate and cost effective repair quotation. Materials specifications are identified through understanding of seal construction, operation and application.

Quotation

All repair quotations are based on specific parts that require refurbishment or replacement. This method is used to reduce repair costs and provide the most economic method of restoring a mechanical seal back to a usable condition.

Seal refurbishment

The refurbishment process restores seals to their original functionality at a fraction of the cost of replacement hardware. Our refurbishment service is available for all standard first4seals products and those of many leading manufacturers, to help prolong a mechanical seal's life span. We are able to repair competitor brands such as: Eagle Burgmann®, Chesterton®, Flowserve®, John Crane® and many more.

We are able to design and reverse engineer competitor components which may have failed in service. Components are modelled using state-of-the-art Computer Aided Design software to produce an accurate model. Components are manufactured using multi-axis CNC machines from a range of materials including standard 316L Stainless Steel, exotic alloys, PTFE and Carbon.

Quality

Quality and customer service are the highest priority and our business is certified to ISO 9001:2015. All repairs are carried out by experienced workshop technicians and monitored by our Technical Team to provide a service which offers a cost-effective and environmentally sound alternative to purchasing new seals. Each seal is pressure tested before it is sent back to the customer. Testing ensures that the seal is in full working order and will perform correctly when installed back into service.



For more information on any of our seals including dimensions, please see the individual brochures available to download from our website.



As the conditions of use are outside the control of first4seals, the information contained within this brochure is given in good faith but without warranty. The above temperature and pressure limits are individual maximum values for SOFT/HARD seal face combinations only. The values are provided for guidance only and are intended for use by suitably qualified application engineers. It is recommended that all users contact the first4seals Technical Department for advice on any new application.



FM61505

UK Sales and Technical Advice:
AESSEAL Marine plc
 Unit 4 Venlo Industrial Estate,
 Knowles Street, Bradford,
 BD4 6HA
 Tel: +44 (0)1274 720775
 Fax: +44 (0)1274 729022
 Email: seals@first4seals.com
 Eeb: www.first4seals.com

Distributed by :

Fenflow Engineering Services
 Kellett gate
 Low Fulney
 Spalding
 Lincs
 PE12 6EH
 01775 725351
 email: info@fenflow.co.uk
www.fenflow.co.uk